

REVISIONS			
REV.	DESCRIPTION	DATE	APPROVED
-	NEW RELEASE	-	-
1	MOUNTING BRACKET WAS FABRICATED NOW PURCHASED. PLATE WASHERS WERE FABRICATED NOW PURCHASED.	4/20/2026	F. BRYANT

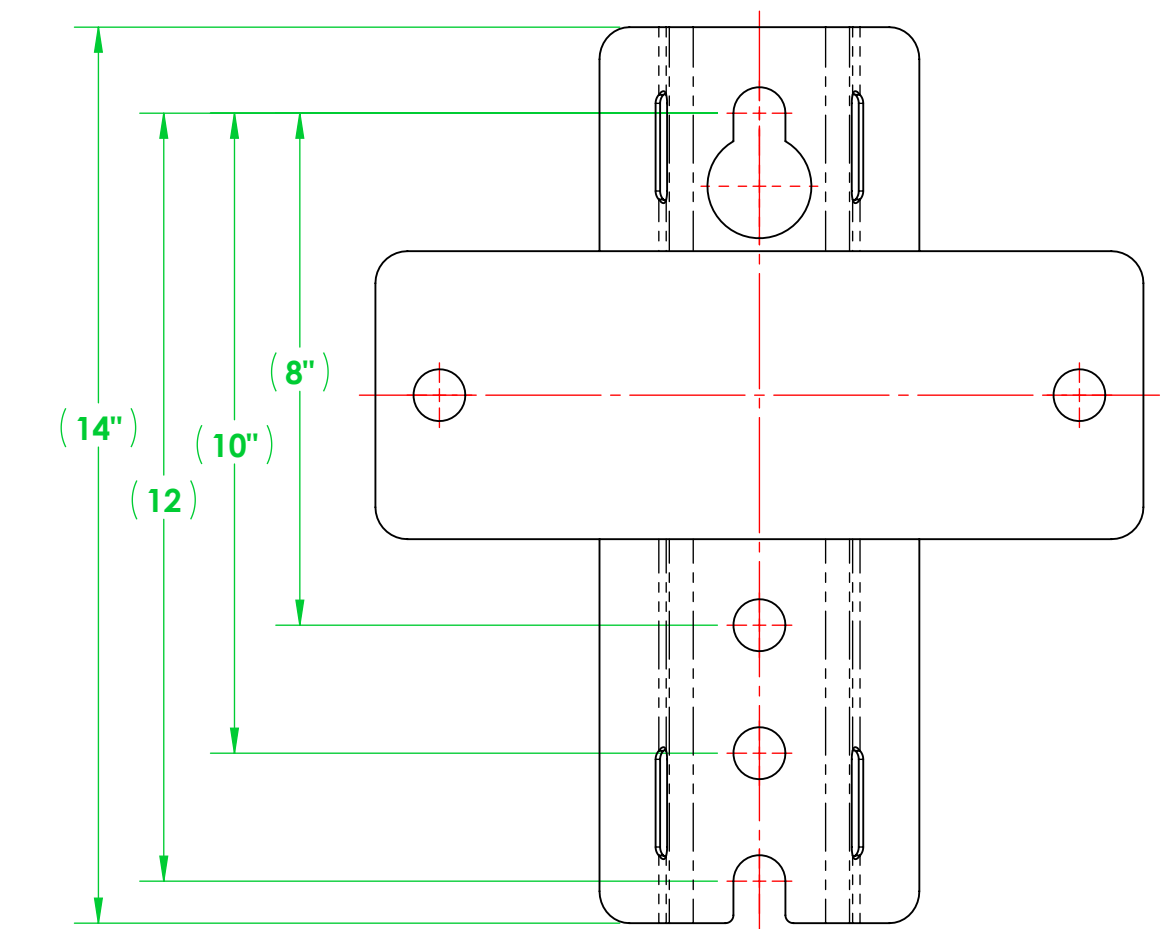

SEE DETAIL A

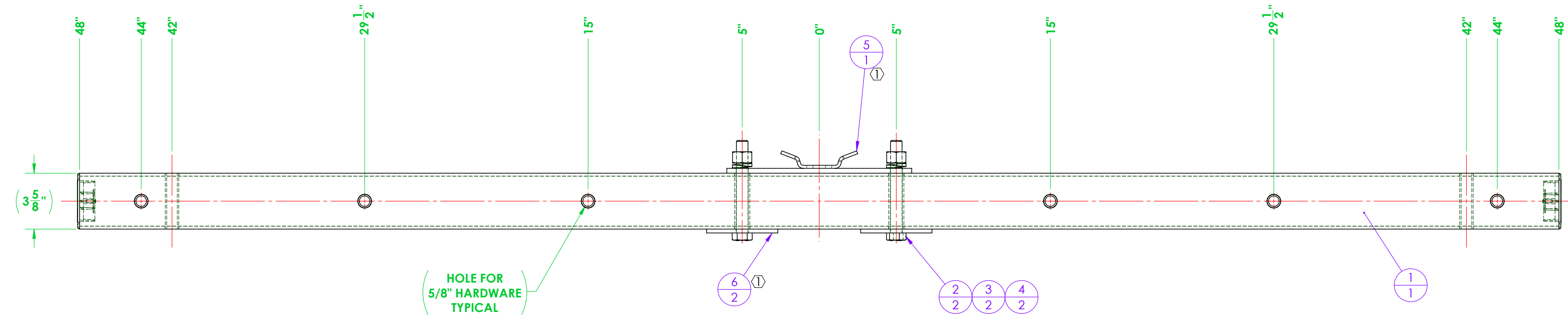
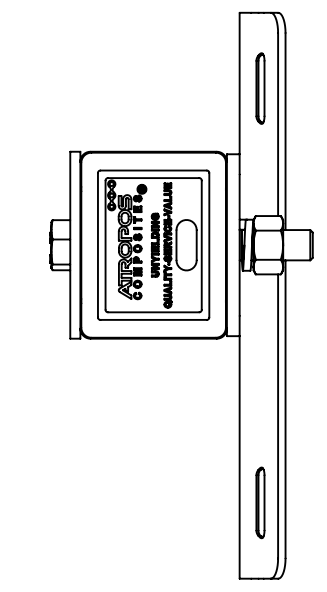
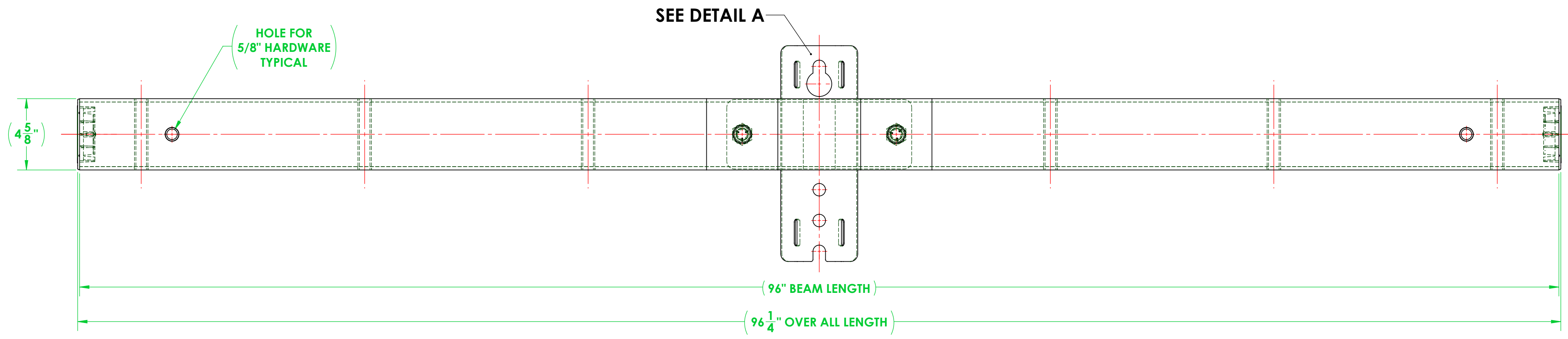

ITEM NO.	PART NUMBER	DESCRIPTION	QTY.
1	3401A096-T011-XR04 CA	ASSEMBLY, RUS, 3401, CROSSARM, TANGENT, 8 FT, AMERMEIN	1
2	A616-0020-02	BOLT, HEX, 3/4"-10 X 6.00" LONG, HOT DIPPED GALVANIZED STEEL, 1-1/8" DRIVE	2
3	A616-0042-01	LOCK WASHER, FOR 3/4" SCREW, 0.766" ID, 1.265" OD, 0.188" THICK, HOT-DIPPED GALVANIZED STEEL	2
4	A616-0019-02	EXTREME STRENGTH NUT, HEX, 3/4"-10, 2H, HOT-DIPPED GALVANIZED	2
① 5	A700-0042	CROSSARM MOUNTING BRACKET, TANGENT, 3400 SERIES	1
① 6	A700-0047	WASHER, SQUARE, 4.625" X 4.625" X 0.25 THICK WITH 0.81 THRU HOLE	2

GENERAL NOTES	UNLESS OTHERWISE SPECIFIED	NAME	DATE
	DIMENSIONS ARE IN INCHES STANDARD TOLERANCES	DRAWN: F. BRYANT	10/13/2025
FRACTIONAL: ±1/32 ANGULAR: MACHINED: +0.5° BEND: ±2° TWO PLACE DECIMAL: ±0.03 THREE PLACE DECIMAL: ±0.005 INTERFERE GEOMETRIC TOLERANCING PER: ANSI Y14.5 MATERIAL: FINISH: DO NOT SCALE DRAWING	CHECKED: TJS	10/21/2025	
	ENG APPR:		
	MFG APPR:		
	Q.A.:		
PROPRIETARY AND CONFIDENTIAL			
THE INFORMATION CONTAINED IN THIS DRAWING IS THE SOLE PROPERTY OF VELLISO. ANY REPRODUCTION IN PART OR AS A WHOLE WITHOUT THE WRITTEN PERMISSION OF VELLISO IS PROHIBITED.			
TITLE: ASSEMBLY, RUS, 3401, TANGENT CROSSARM WITH GAIN, 8' TYPE 4 DRILL PATTERN		SIZE DWG. NO. D 3401A096-T011-XR04	REV 1
SCALE: 1:8		WEIGHT: 48.72	SHEET 1 OF 1

